

# Lockout Lever Kit for Master Disconnect Switch

**24505** for 5/16" shackle locks

**24505-01** for 7mm shackle locks

This kit may be used with all Cole Hersee *metal* lever-activated master Disconnect Switches with a 3/4 diameter mounting stem.

**Use this kit to secure the switch in the Off position with a padlock. Such lockout procedures may be required by regulations, particularly in situations where moving machinery might be accidentally turned on causing risk of injury.**

## In Package

- Locking Lever
- Bracket
- 10-32x3/8" Screws (2)

## Installation

1. Make sure that the switch is in the off position
2. **Warning** — Disconnect all battery cables from the battery before attempting to install this product
3. Remove the lever from the switch. Retain the existing screw and lock washer as these are required to attach the locking handle
4. Remove the hex nut and lock washer from the mounting stem
5. Place the bracket over the stem
6. Replace hex nut on mounting stem and tighten only finger tight
7. Put The locking handle on the switch and replace lock washer and screw from original lever. Tighten finger tight
8. Rotate bracket until the hole in handle lines up with the hole in the bracket.
9. Mark the center of the mounting screw holes

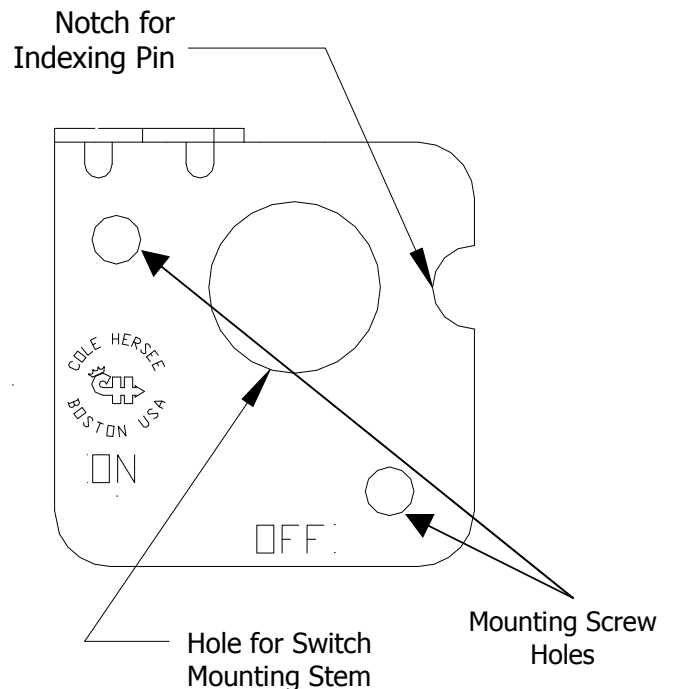
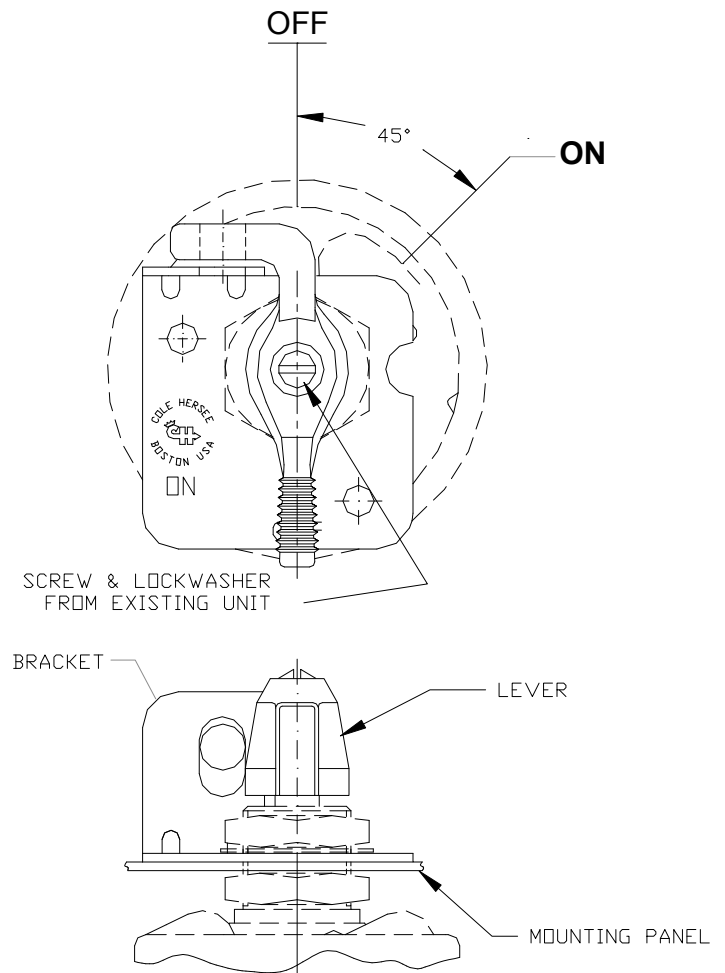

10. Remove the handle with screw and lock washer

11. Remove the Mounting nut and lock washer from the stem
12. Remove the switch from the panel
13. Drill two 5/32" holes at the marks from the bracket
14. Attach the bracket with the two screws provided
15. Place the switch through the hole in the bracket
16. Replace the lock wash and nut on the stem of the switch and tighten finger tight.
17. Replace the locking handle on the switch using the screw and lock washer from the original lever.
18. Rotate the switch until the hole on the top of the bracket lines up with the hole on the locking handle.
19. Tighten the hex nuts to a maximum torque of 20 ft-lbs.

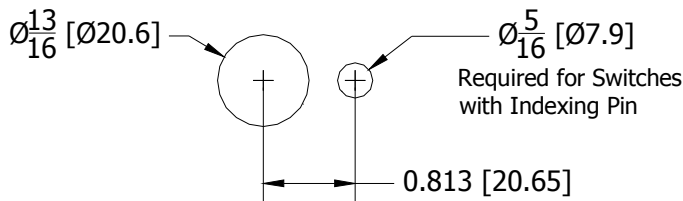

Standard Master Disconnect Mounting Pattern

## Other Cole Hersee Battery Management Products



- 48510 200A Low Voltage Disc.**
- 48511 100A Low Voltage Disc.**
- 48512 150A Low Voltage Disc.**



**48513 125A Compact LVD**



- 48530 200A Smart Isolator**
- 48525 85A Smart Isolator**

Direct Questions to [engineering@colehersee.com](mailto:engineering@colehersee.com)

Please consult the factory if you need further assistance

**617-268-2100**

**8am — 4:30 PM Eastern Time**

[www.colehersee.com](http://www.colehersee.com)

**IF-153** Rev. B

 **Cole Hersee Co.**